

BRISTAN

Installation Instructions & User Guide

Please leave these instructions with the end user

Product Code: SOLO-NMT LL (D1)

Specifications

Dynamic Water Pressure

Min: 0.5 bar Max: 5.0 bar

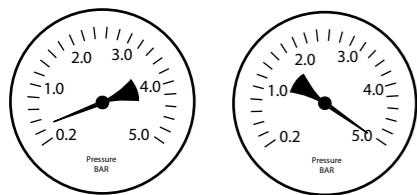

Maximum Static Pressure: 10.0 bar

Inlet Water Temperature

Cold Water Supply

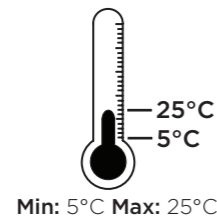

Min: 5°C Max: 25°C

Hot Water Supply

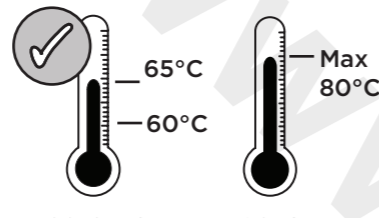

60-65°C recommended
80°C Maximum

Inlet Connections

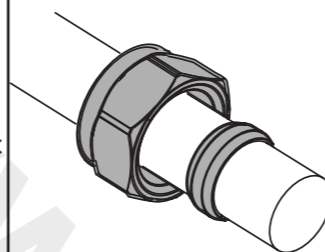

15mm
Compression

Tools You'll Need

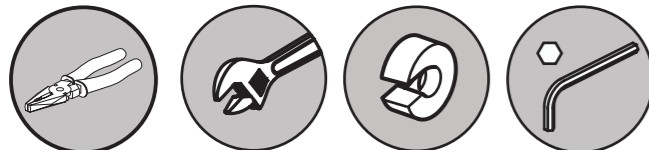

Pliers Adjustable Spanner Pipe Cutter Hexagonal Keys

Servicing Your Tap

We recommend servicing your tap at least once every year to prolong its life. To see a video showing how to remove the cartridge for servicing, scan the QR code with your smart phone or tablet.



Alternatively visit www.bristan.com/howto

Prior to Installation

All products manufactured and supplied by Bristan are safe provided they are installed, used correctly and receive regular maintenance in accordance with these instructions.

These taps need to be installed in accordance with, and meet the requirements of the Water Supply (Water Fittings) Regulations 1999 and Scottish Byelaws 2004.

Isolation valves must be fitted to the inlet water supplies to ensure ease of future maintenance (not supplied).

Before installing these taps the water supply must be thoroughly flushed in order to remove any swarf, solder etc.

This product must not be modified in any way as this will invali-

Pack Contents

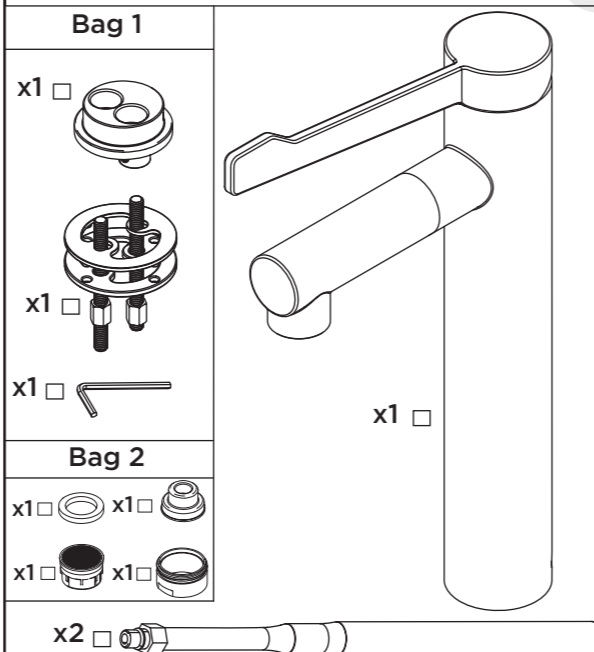

Installation

1

Screw the fixing kit rods into the base

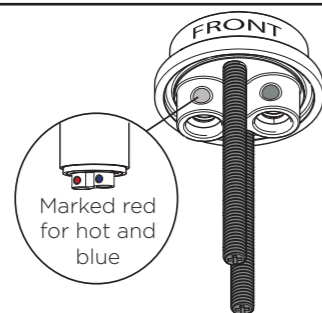

2

Drop the base into the basin hole, ensuring the O-Ring is underneath.

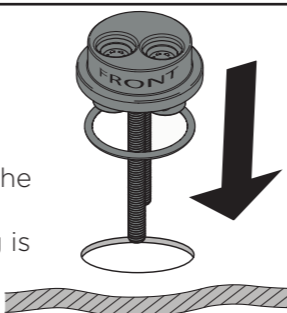

3

Slide the washers up to the underside of the basin and tighten the fixing nuts until they are against the washers.

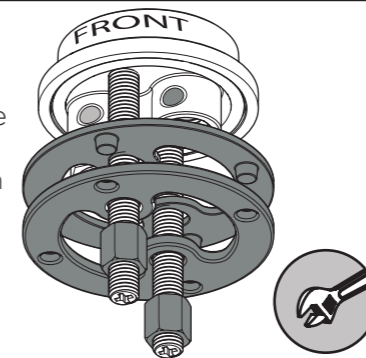

4

Screw the copper tails into the base by hand.

DO NOT OVERTIGHTEN

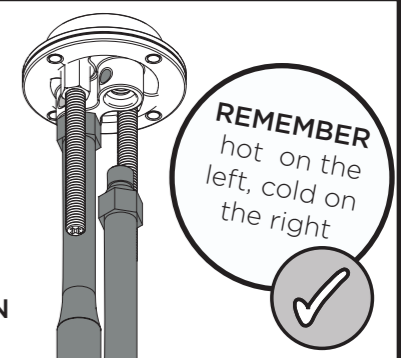

5

Connect the copper pipes to the water supply.

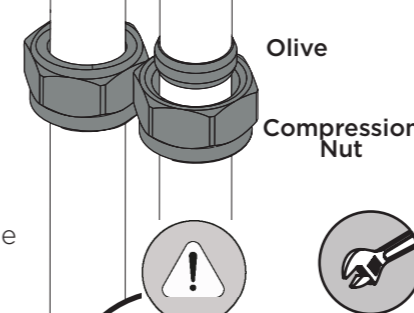

IMPORTANT
fit isolation valves for future maintenance

6

Push tap body onto the tap base and secure with grub screws.

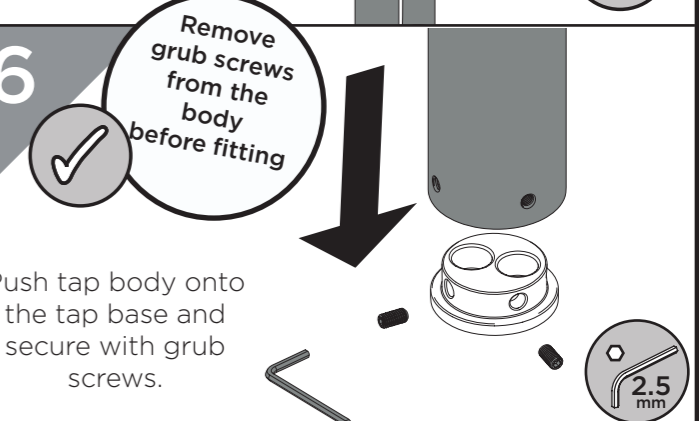

7

Turn on the water supply. Check all joints and connections for any leaks.

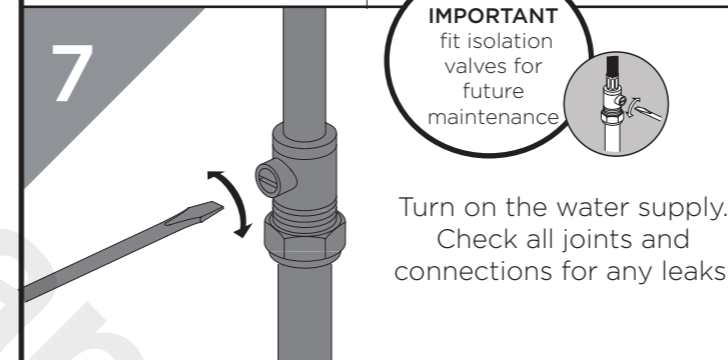

8

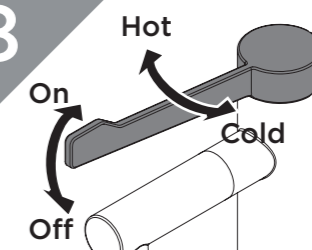

Your tap is now ready to be commissioned to ensure correct operation.

General Cleaning

Your fitting has a high quality finish and should be treated with care to preserve the visible surfaces.

All surfaces will wear if not cleaned correctly, the only safe way to clean your mixer tap is to wipe with a soft damp cloth. Stains can be removed using washing up liquid. All bath cleaning powders and liquids will damage the surface of your fitting, even the non-scratch cleaners.

Note: Never use abrasive detergents or disinfectants or those containing alcohol, hydrochloric acid or phosphoric acid.

Commissioning - Choosing Outlet

1

Push your desired outlet into the outlet housing, ensuring the washer is in place.

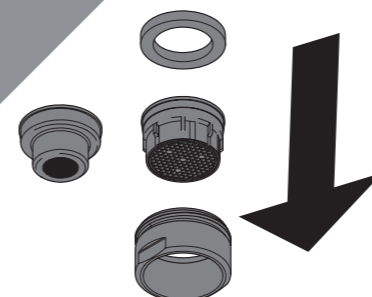

2

Place the assembled outlet housing into the tap spout.

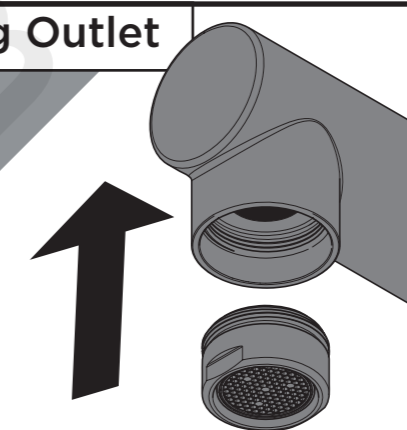

3

Put the anti-splash into the tap body and tighten in place

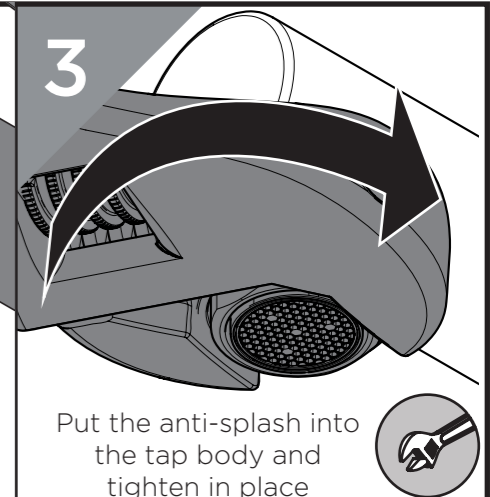

Commissioning - Temperature Adjustment

1 Remove cap. Undo grub screw and remove handle. **IMPORTANT** Isolate the water supply before starting!

2 Unscrew shroud and retaining nut. Remove cartridge.

3 Pull off the adjustment ring on the cartridge to adjust to the desired temperature as shown below. Turn the adjustment ring to this position for an approximate temperature of 41°C.

4 Push the adjustment ring back in place. Replace cartridge. Screw on retaining nut and shroud.

5 Replace handle. Tighten the grub screw and replace the cap.

6 Turn on the mains water supply, letting the water flow for a few minutes to flush through the system.

Maintenance - Changing Flow Limiter

1 Unscrew the grub screws and lift off the tap body. **IMPORTANT** Isolate the water supply before starting!

2 Remove the flow limiters from the inner pipes, replacing with your chosen flow limiters.

3 Push tap body onto the tap base and secure with grub screws.

4 Turn on the mains water supply, letting the water flow for a few minutes to flush through the system.

Maintenance - Cleaning/Replacing Cartridge

1 Remove cap. Undo grub screw and remove handle. **IMPORTANT** Isolate the water supply before starting!

2 Unscrew shroud and retaining nut. Remove cartridge.

3 Place cartridge in a suitable solution and soak until fully descaled.

4 Replace cartridge. Screw on retaining nut and shroud.

5 Replace handle. Tighten the grub screw and replace the cap.

6 Turn on the mains water supply, letting the water flow for a few minutes to flush through the system.

Troubleshooting

Symptom	Cause(s)	Remedy
No flow or low flow rate	Partially closed isolation valve.	Open isolation valve.
	Instantaneous water heater cycles on and off as flow rate or pressure is too low.	Increase water flow rate or pressure through system.
	Head of water is below the minimum distance required.	Refer to the specification for the minimum distance required
	Hot or cold water being drawn off elsewhere causing pressure changes or instantaneous boiler temperature changes.	Do not use other water outlets when using the taps.
	Airlock or partial blockage in the supply pipework.	Flush through pipework to ensure removal of debris and any airlocks.
	Water supply failure, please check below:	Investigate water supply. Check your plumbing and heating systems for any faults.
	When handle is in Hot Position	
When handle is in Cold position	fault on the cold water supply. Hot water will still continue to run.	
Water dripping from taps	This is normal for a short time after using the taps.	This is caused by capillary action, the build up of water in the tap body.
	If water continues to drip, possibly due to the ceramic disc valves/cartridge	Refer to the section: Maintenance - Cleaning/Replacing Cartridge
Taps do not turn on	Closed isolation valve.	Open isolation valve.
	Mains water supply turned off.	Turn on mains water supply.

Maintenance - Changing Spout

1 Remove the grub screw from the spout. **IMPORTANT** Isolating the water supply is advised!

2 Remove spout from tap body. Replace with desired spout.

3 Secure the spout to tap body with grub screw. Ensure the spout is straight.

Two styles of spout available! See our Quick Start Guide for more details.

At Bristan, we want to make things as easy as possible for our customers. That's why we offer solid guarantees on all our products, effective from the date of purchase, to give you peace of mind.

To start your free guarantee simply scan the QR code and register your product. Alternatively visit www.bristan.com/register.

For any other queries, please call our Customer Service on 0330 026 6273 where our expert team of advisors will be able to offer you any help and advice.

For full guarantee terms and conditions visit www.bristan.com/guarantees.



We Know & We Care